

DATA FROM
 DON FAIRBANKS
 CARDINAL AIR TRAINING, INC.
 AND
 VERNON PAYNE
 KNIGHT TWISTER AIRCRAFT
 RT. 4, BOX 319M
 ESCONDIDO, CALIF. 92025
 DRAWING APPROVED BY
 DON FAIRBANKS, PILOT/OWNER.

DON FAIRBANKS
 KNIGHT TWISTER IMPERIAL
 WING AREA 75 SQ. FT. PLUS FUSELAGE (82 FT.)
 POWER - LYCOMING 0-290-D2
 COLOR - WHITE, ORANGE TRIM 
 1971 RACING SEASON:
 WILSON N.C. TRIAL - 1ST.
 CAPE MAY N.J. 3RD IN FINAL, 158.4 MPH
 RENO, NEV. - NO 5 PAINTED AS N 5 DF
 MAY 1971 NO. 5D SHOWN BELOW.
 NACA 21 AIRFOIL - .10

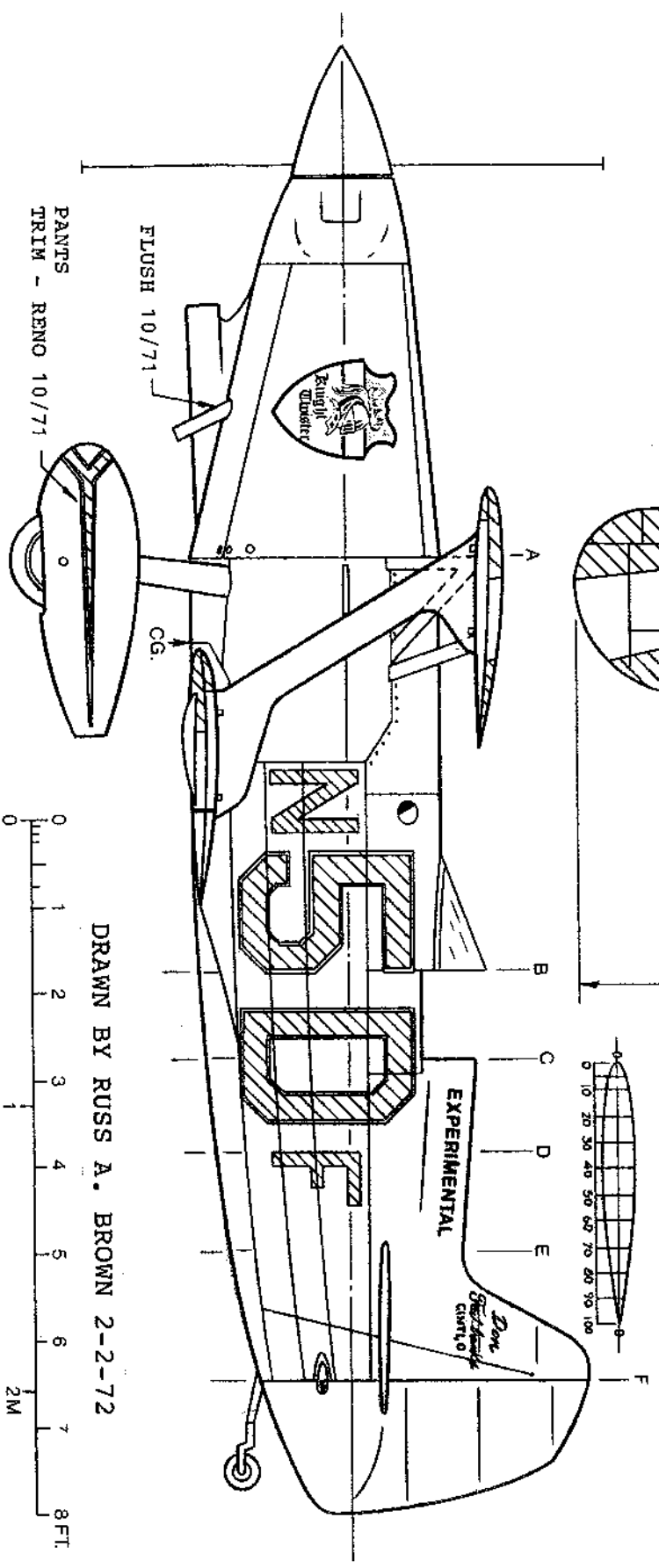

DRAWN BY RUSS A. BROWN 2-2-72
 0 1 2 3 4 5 6 7 8 FT
 2M

Russ A. Brown